

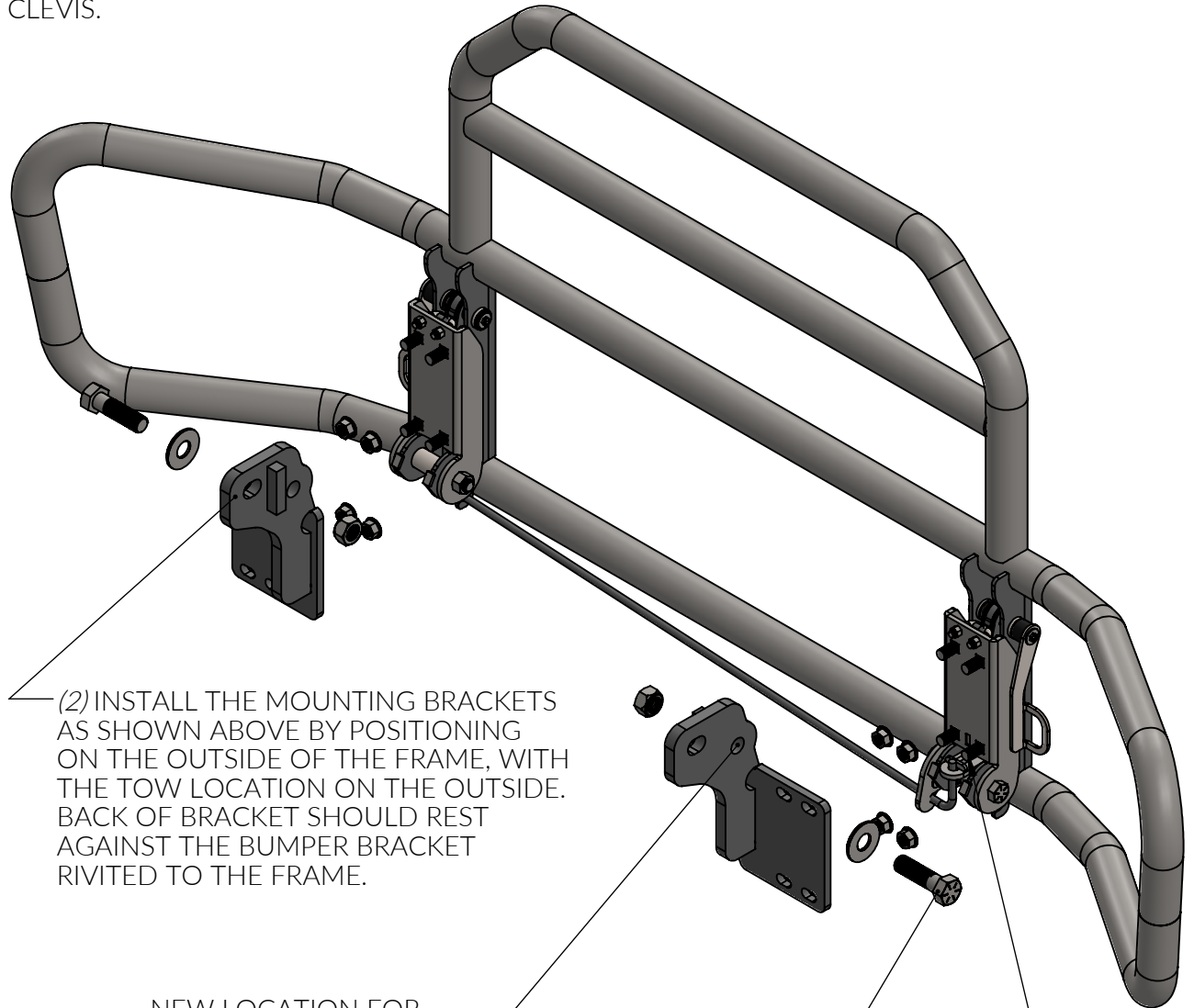

MOUNTING INSTRUCTIONS - XG-99MC MT REV1

CALL: (888) 902-2777 FOR INSTALLATION QUESTIONS OR EMAIL: INFO@EX-GUARD.COM

(1) LOCATE AND REMOVE THE CLEVIS TOW LOOP, BY REMOVING THE COTTER PIN AND PULLING THE 1 INCH PIN OUT OF THE CLEVIS.



(2) INSTALL THE MOUNTING BRACKETS AS SHOWN ABOVE BY POSITIONING ON THE OUTSIDE OF THE FRAME, WITH THE TOW LOCATION ON THE OUTSIDE. BACK OF BRACKET SHOULD REST AGAINST THE BUMPER BRACKET RIVITED TO THE FRAME.

NEW LOCATION FOR CLEVIS REMOVED IN NOTE 1.

(3) INSERT 1 INCH BOLT SUPPLIED THROUGH THE BRACKET AND THROUGH THE HOLE IN THE FRAME WHERE THE CLEVIS USED TO BE. INSERT FLAT WASHER AND NUT TORQUE TO 644 FT LBS.

(4) INSTALL EX-GUARD BY: INSERTING STUDS INTO MOUNTING BRACKETS AND TORQUE TO 150 FT/LBS

IMPORTANT!! Any Ex-Guard grille guard, bracket kit, or hardware must be used with corresponding Ex-Guard components. Use of any other product or brand with Ex-Guard products will immediately void the warranty provided by Ex-Guard Industries.

© THIS DRAWING IS THE PROPERTY OF EX-GUARD INDUSTRIES, INC. COPYRIGHT IS RESERVED BY THEM AND THE DRAWING ISSUED ON CONDITION THAT IT MUST NOT BE USED FOR ANY OTHER PURPOSE OTHER THAN FOR WHICH IT WAS SUPPLIED AND NOT TO BE COPIED, REPRODUCED, RETAINED OR DISCLOSED TO ANY UNAUTHORIZED PERSON EITHER WHOLLY OR IN PART WITHOUT THE CONSENT IN WRITING OF EX-GUARD INDUSTRIES INC.

